

## Istruzione di montaggio *Assembly Instruction* *Instructions de Montage*

- **Posizionare le guide rispettando le quote indicate ed avvitarle con le apposite viti sui fianchi del mobile.**  
*Place slides respecting showed data and screw them on the cabinet's sides.*  
*Positionez les glissières en respectant les mesures indiquées et serrez les vis sur les côtés du meuble.*

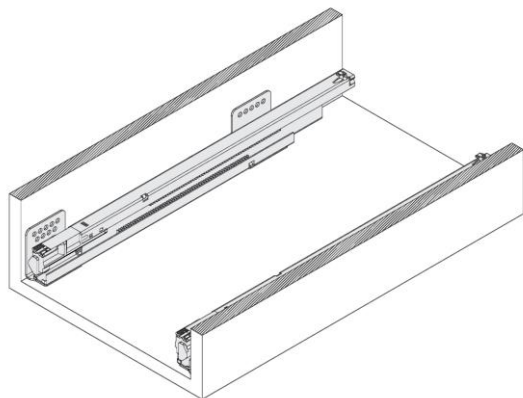

| Dimensione Guida<br>Slide Dimension<br>Dimensions Glissière | X      |
|---|--------|
| 450   | 288 mm |
| 500   | 320 mm |

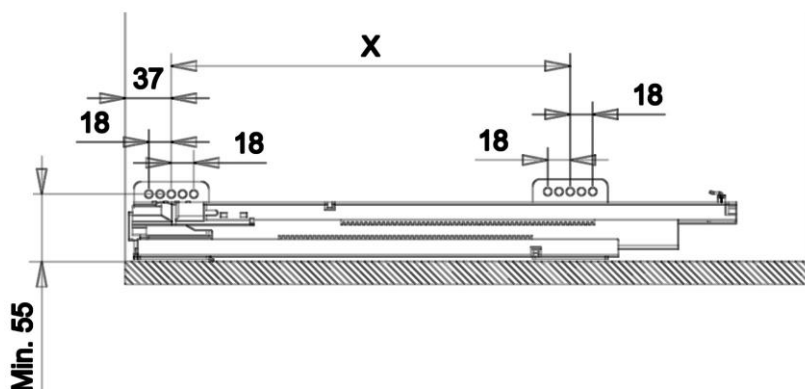

- **Posizionare i carter sulle guide facendoli aderire bene. Posizionare il cesto al centro del mobile e serrarlo con le apposite viti sui carter.**  
*Place covers making them sticking well to the slides. Place basket at the centre of the cabinet and screw it on the covers*  
*Placez les carters sur les glissières les faisant bien adhérer. Placez le panier dans le centre du meuble et serrez les vis sur les carters.*

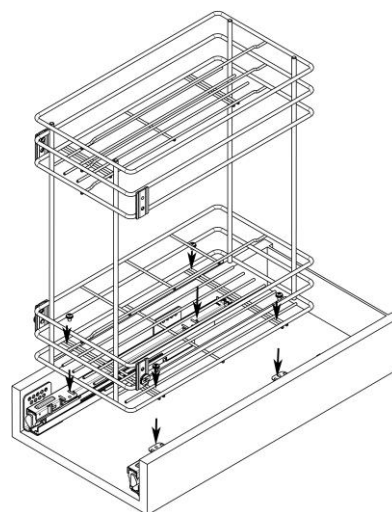
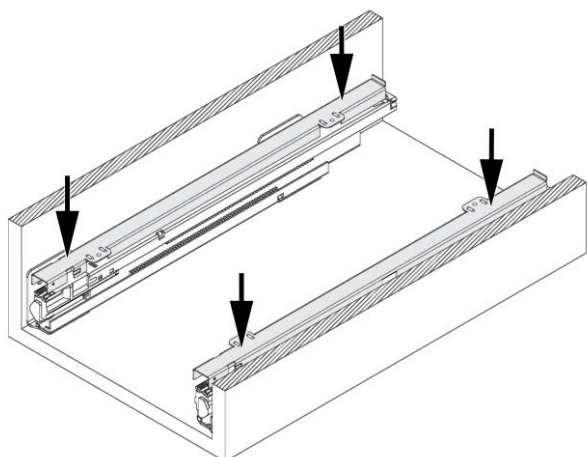

**N.B.:** Tutte le quote sono espresse in mm ed hanno tolleranza +/- 1 mm.

*All data are in mm and the tolerance is +/- 1 mm.*

*Toutes les dimensions sont en mm et ont une tolérance de +/- 1 mm.*

- **Avvitare i piastrini sull'antina rispettando le misure indicate.**  
Screw plates on the door respecting showed data.  
Vissez les plaques sur la porte en respectant les mesures indiquées.

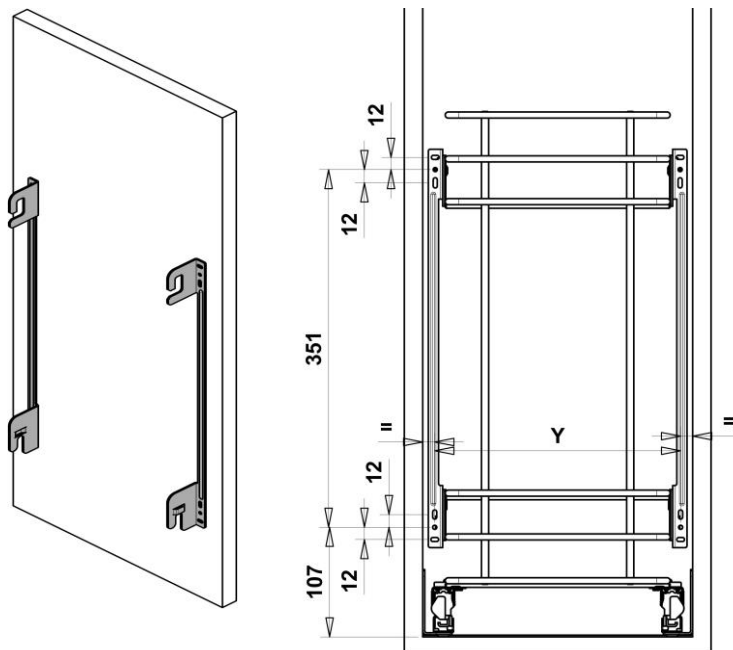

| Dimensione Mobile<br>Size Furniture | Y      |
|-------------------------------------|--------|
| 300                                 | 240 mm |
| 400                                 | 340 mm |
| 450                                 | 390 mm |
| 600                                 | 540 mm |

- **Una volta montata l'antina effettuare le regolazioni agendo sulle varie viti**  
Once assembled the door adjust it by acting on the various screw  
Une fois monté la porte, faire des ajustements sur les vis.

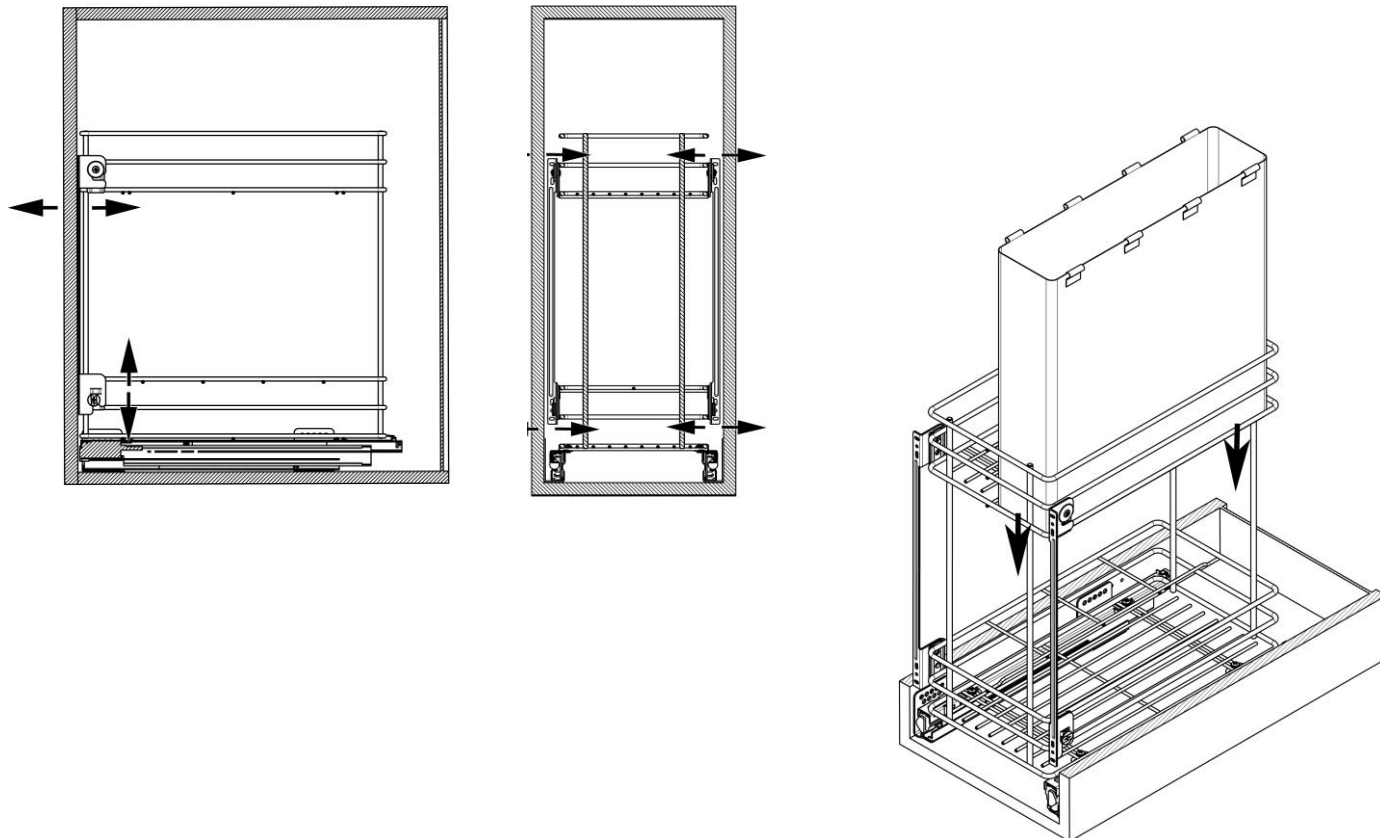

**N.B.:** Tutte le quote sono espresse in mm ed hanno tolleranza +/- 1 mm.

All data are in mm and the tolerance is +/- 1 mm.

Toutes les dimensions sont en mm et ont une tolérance de +/- 1 mm.