



ART 002i H685 ART 002+ H685

GUIDE SIGE - SIGE SLIDES - COULISSES SIGE - GUIAS SIGE

REV 00.2023

FOIST00401

SIGE S.P.A.

60020 POLVERIGI (AN) ITALY

TEL +39 071 90 90 000 R.A. - FAX +39 071 90 90 804

WWW.SIGE-SPA.IT INFO@SIGE-SPA.IT

PRODOTTO ED ASSEMBLATO IN ITALIA / MADE AND ASSEMBLED IN ITALY / FABRIQUÉ ET ASSEMBLÉ EN ITALIE / HECHO Y MONTADO EN ITALIA

CARATTERISTICHE • FEATURES • CARACTÉRISTIQUES • CARACTERÍSTICAS

Cestello jolly fondo in nobilitato con guide sx ad estrazione totale con soft e kit divisori.
Solid base pull-out base basket with soft close, left full extension slides and spacers.
Panier bas coulissant avec glissières sortie-totale gauches et soft closing. Panier fond mélaminé.
Cesto jolly en asiento laminado con guias izquierdas a extracción total con soft y kites de división.

MINUTERIA INTERNA • FITTINGS • FERRURE • FERRETERIA

N° 12 4x16 mm Viti autofilettante / Self-tapping screws / Vis auto-taraudeuses / Tornillos autorroscantes

N° 8 3,9x13 mm Viti autofilettante / Self-tapping screws / Vis auto-taraudeuses / Tornillos autorroscantes

N° 4 M5x8 mm Viti / Screws / Vis / Tornillos

COMPONENTI • PARTS • COMPOSANTS • COMPONENTES

A. N°1 002i H685 Cestello / Basket / Panier / Cesto

B. N°1 002+ H685 Cestello / Basket / Panier / Cesto

C. N°1 Set guide sx / Set slides left / Kit glissières gauches / Set de guias izquierdas

D. N°2 Staffe per fissaggio antina / Door brackets / Pattes fixation porte / Estribos para ajuste de puerta

E. N°4 002i Divisorio porta bottiglie / Bottles dividers / Séparateurs bouteilles / Divisorios botellas

F. N°4 002+ Divisorio porta bottiglie / Bottles dividers / Séparateurs bouteilles / Divisorios botellas

UTENSILERIA • TOOLS • OUTILS • INSTRUMENTOS



MANUTENZIONE • MAINTENANCE • ENTRETIEN • MANTENIMIENTO

Pulire con un panno morbido ed asciutto. Evitare l'uso di solventi e/o abrasivi.

Clean with a soft, dry cloth. Avoid using solvents or abrasive.

Nettoyez avec un chiffon sec et doux. N'utilisez pas aucun solvant ou produit abrasif.

Limpiar con paño suave y seco. Evitar el uso de solventes y/o abrasivos.

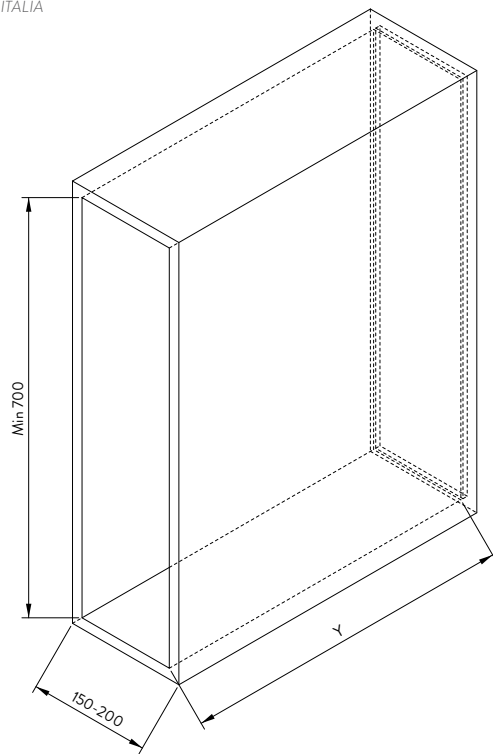

	002i	002+
Y	500	515

ART 002i

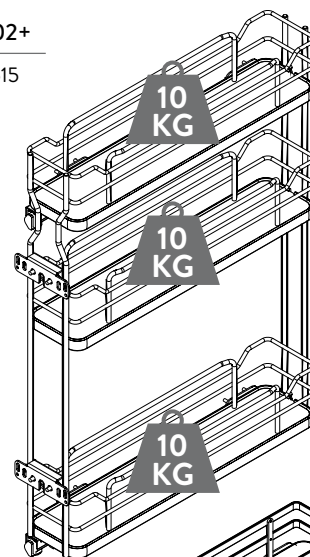

ART 002+

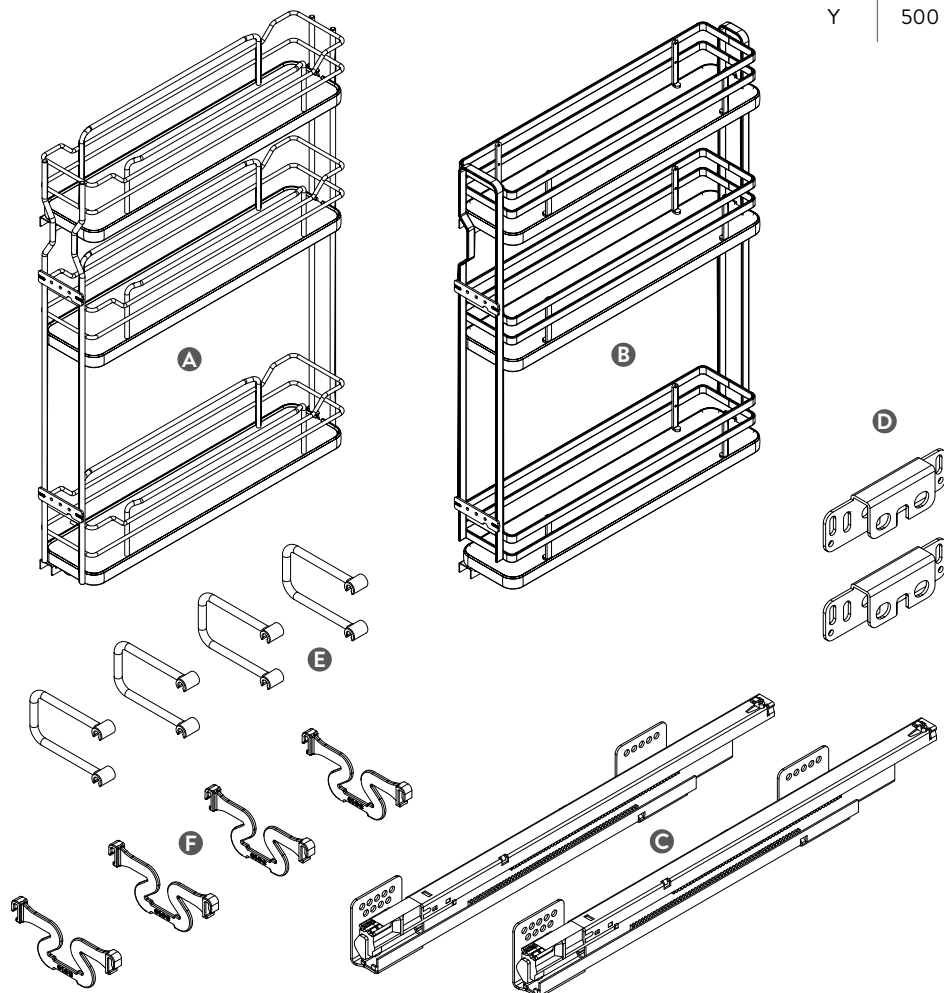
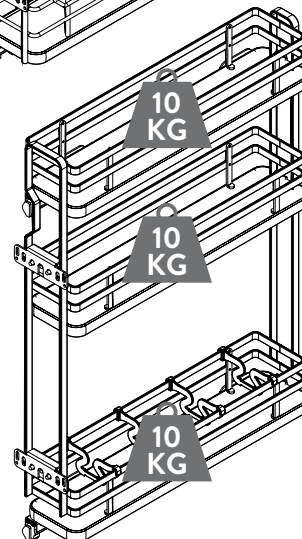

N°12 4x16



1

Posizionare le guide C rispettando le quote ed avvitare con le apposite viti.

Positionnez les glissières C en respectant les mesures indiquées et serrez les vis.

Place slides C respecting showed data and screw them.

Posicionar las guías C respetando las medidas y atornillar con sus debidos tornillos.

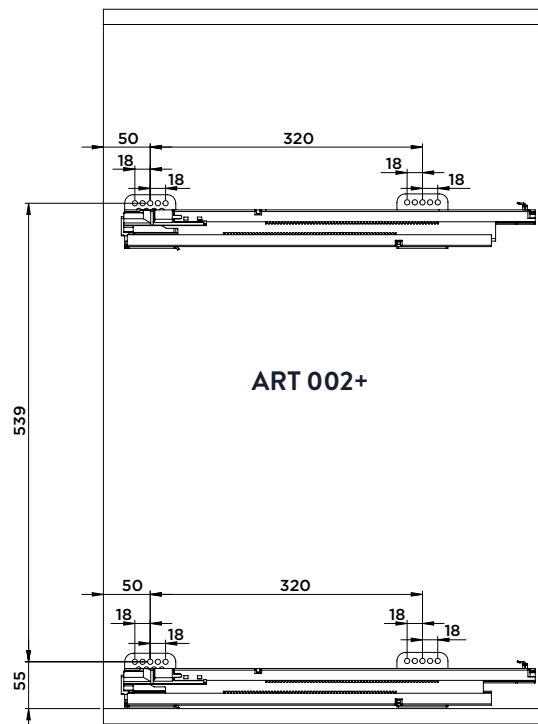
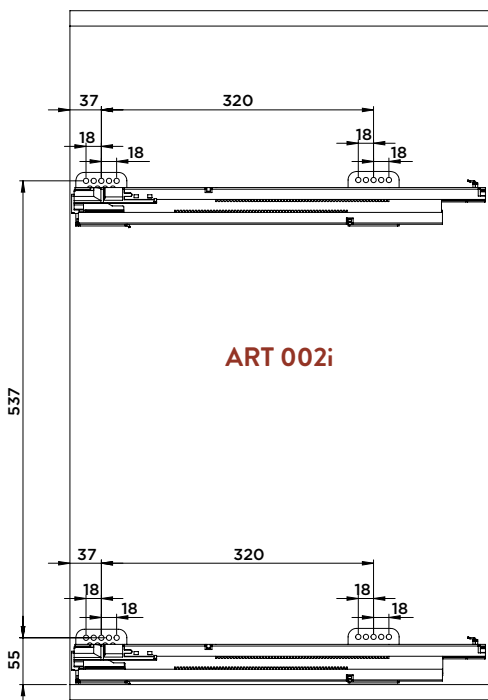
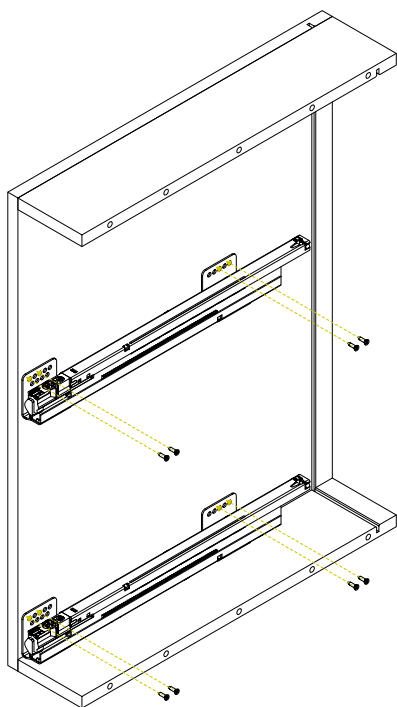

N°6 3,9x13



2

Avvitare le staffe antina D sull'antina rispettando le misure indicate.

Screw door bracket D on the door respecting showed data.

Visser les pattes de fixation D sur la porte en respectant les mesures indiquées.

Atornillar los estribos D sobre la puerta respetando las medidas indicadas.

	002i	002+
Z	166	158

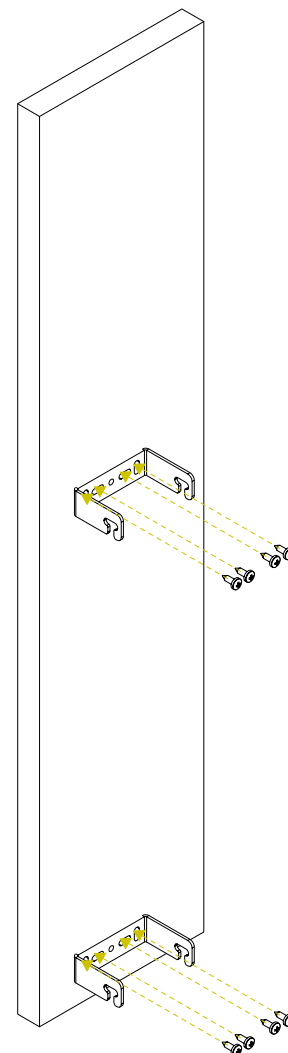
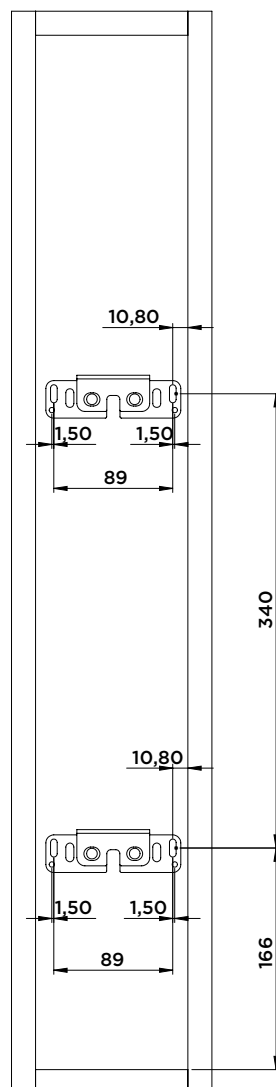

N° 4 M5x8



3

Montare il cesto A/B sulle guide C.
Fit basket A/B on slides C.

Montez le panier A/B sur les glissières C.
Montar el cesto A/B sobre las guías C.

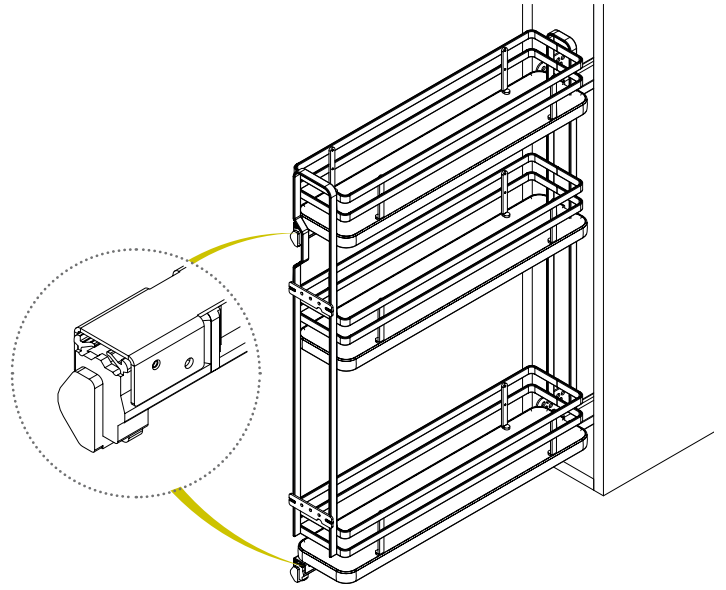
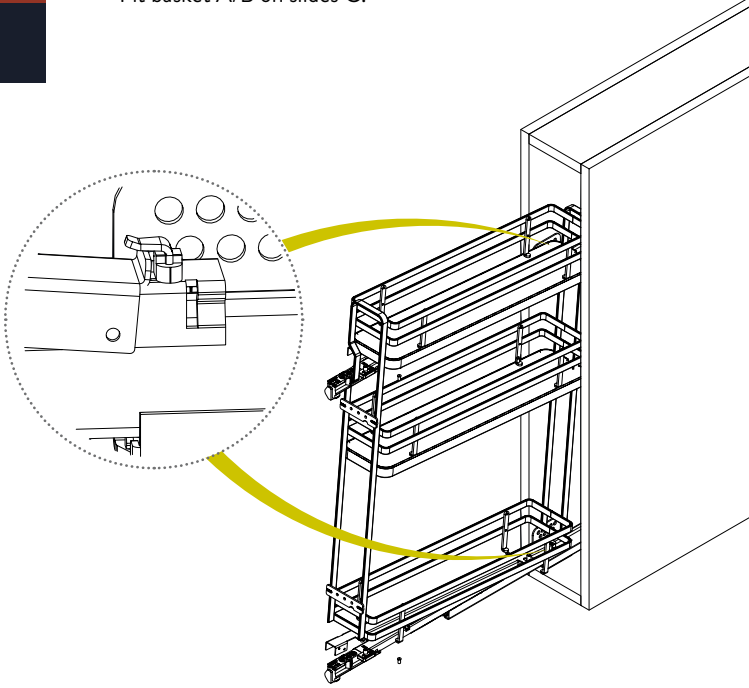

N°4 M5x8



4

Montare l'antina sul cesto A/B.
Fix the door on basket A/B and screw.
Montez la porte sur le panier A/B et vissez.
Montar l'estribo sobre el cesto A/B.

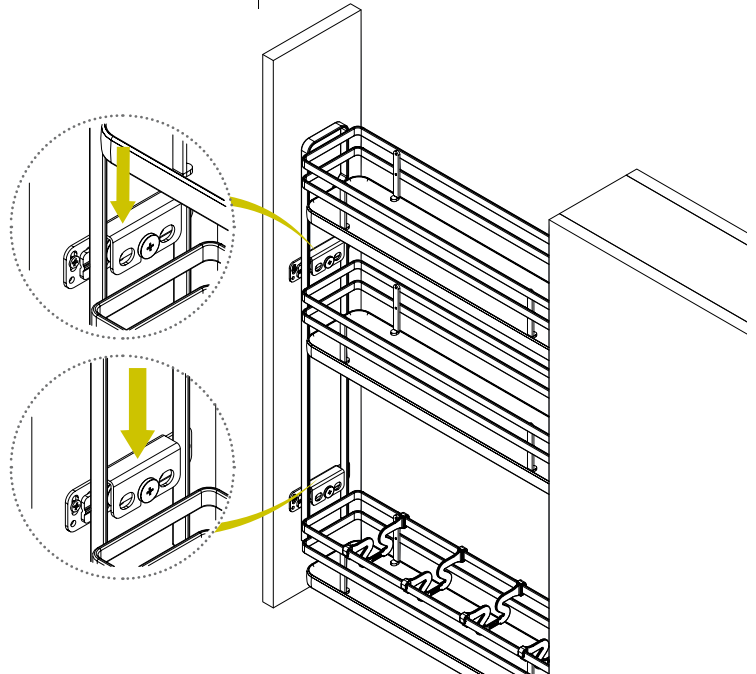
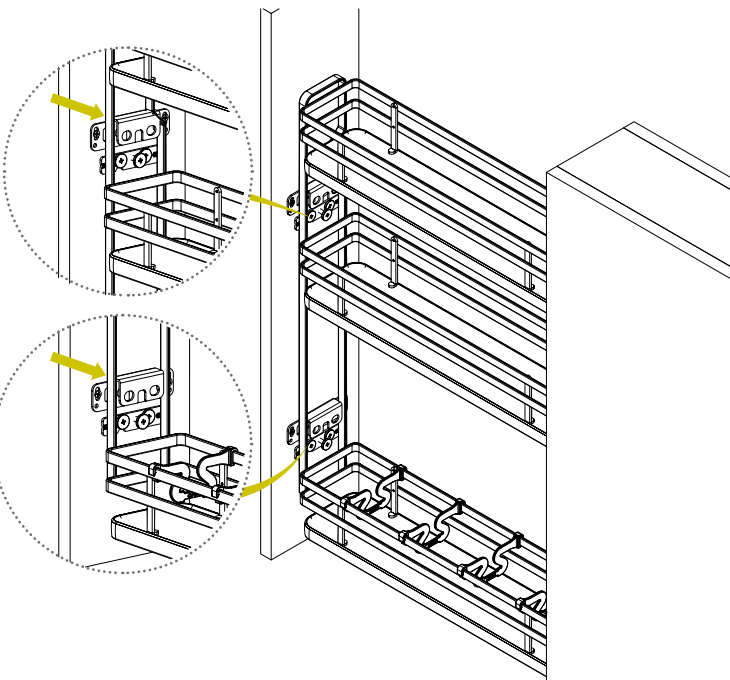
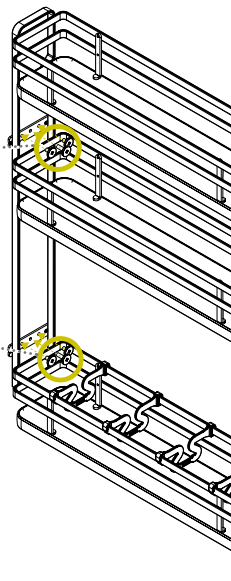
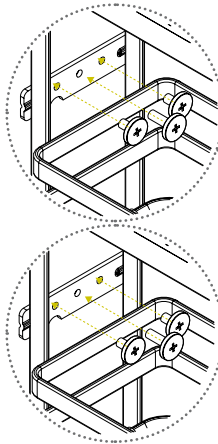



5

Effettuare le regolazioni.
Go on with the adjustments.

Faites les réglages.
Efectuar las regulaciones.

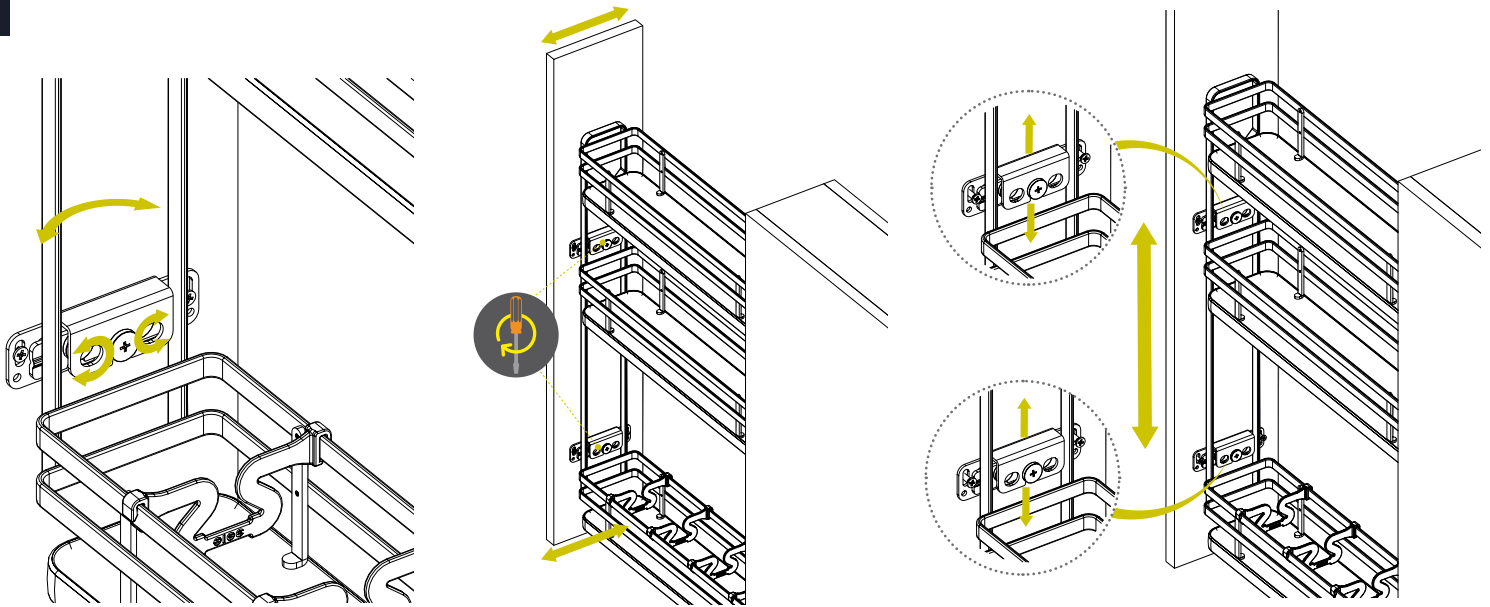

6

Inserite i divisori porta bottiglie E o F.
Insert bottles dividers E or F.
Insérez les séparateurs bouteilles E ou F.
Insertar los divisorios para botellas E o F.

PART. 065D

PART. 065D+

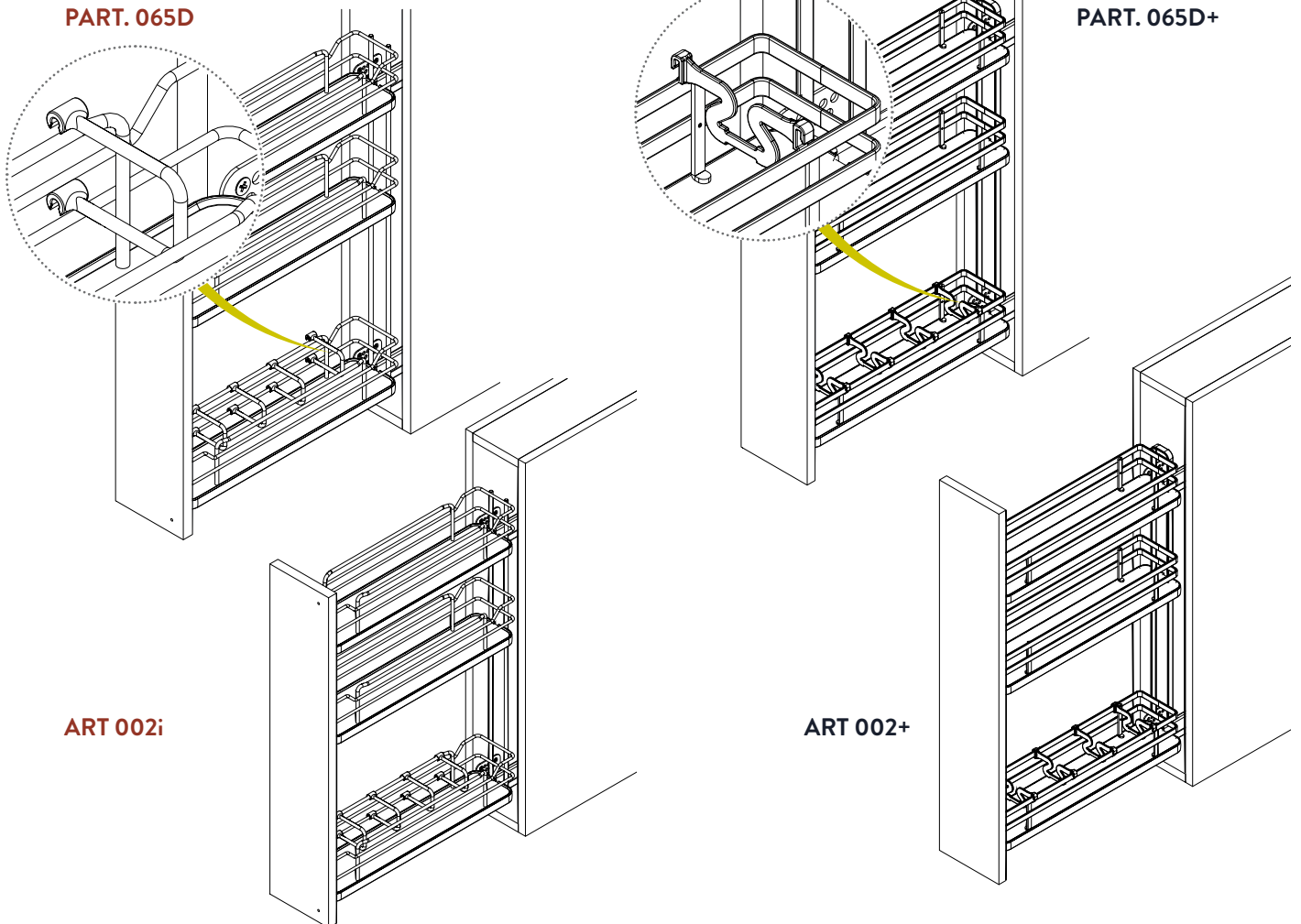

ART 002i

ART 002+